

Fill the upper and lower sections with a block of fiberglass insulation staying about an inch away from the back of the woofers. If using the Blackhole 5 upgrade cover all walls with it.

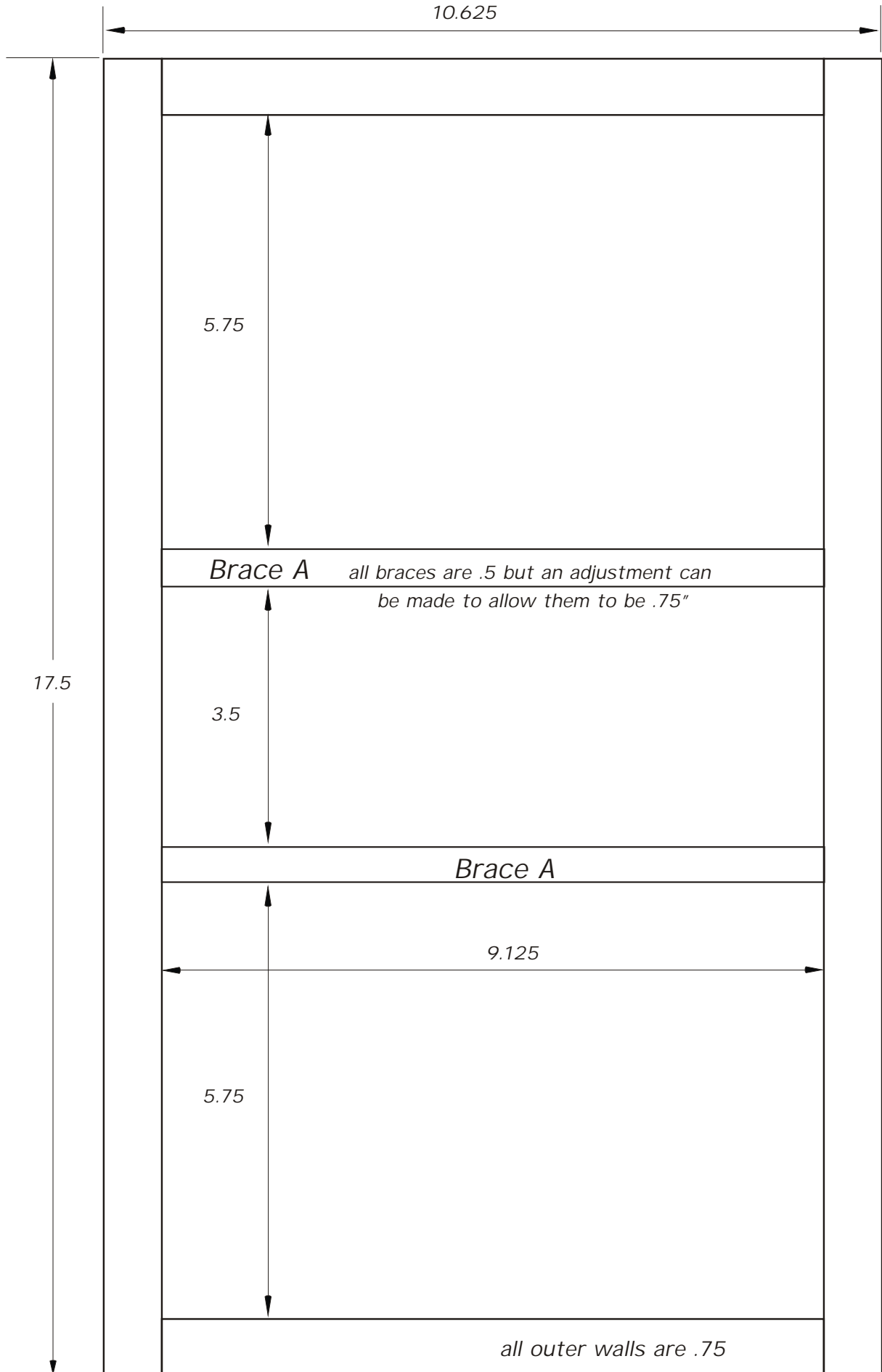

*upright version*

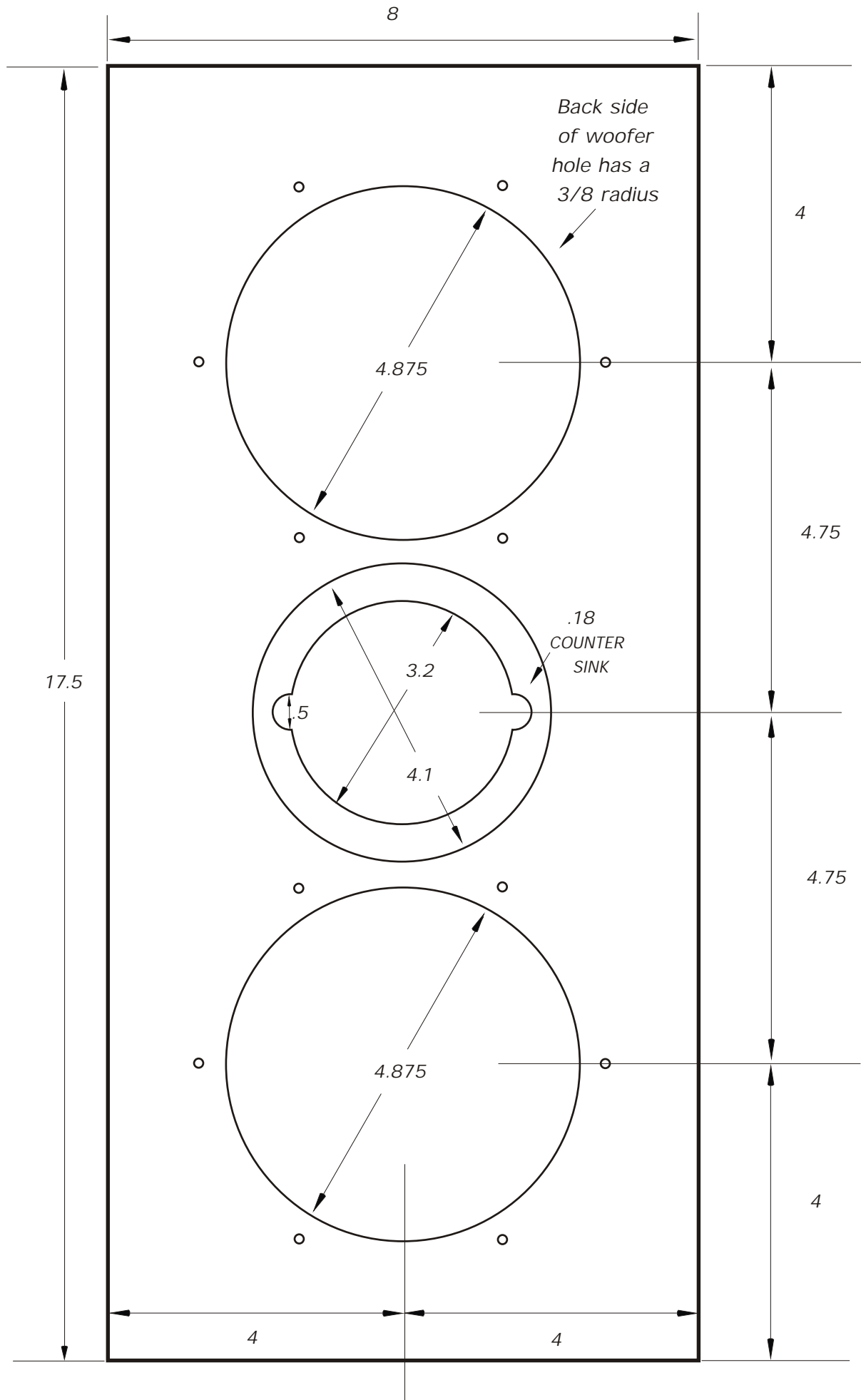



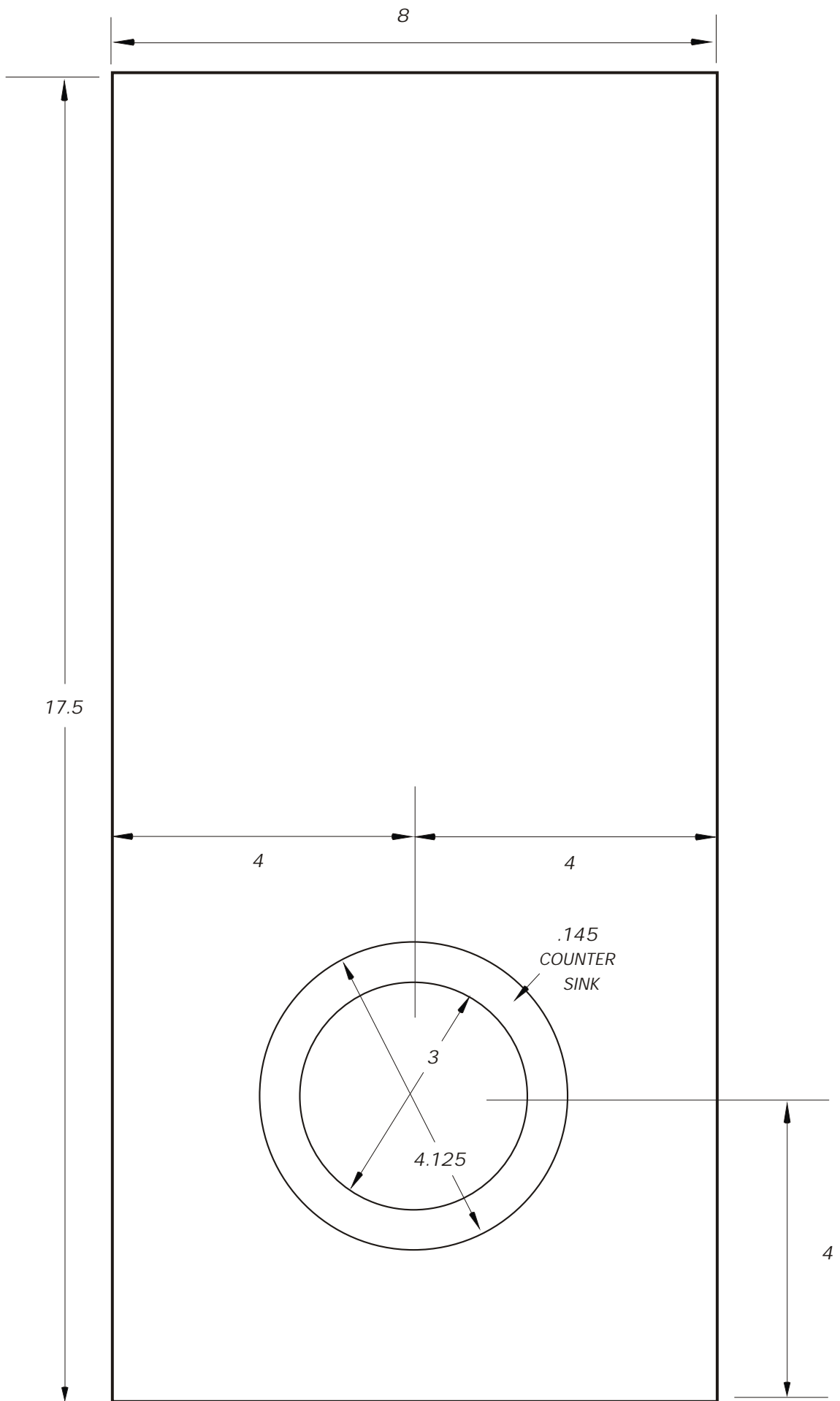

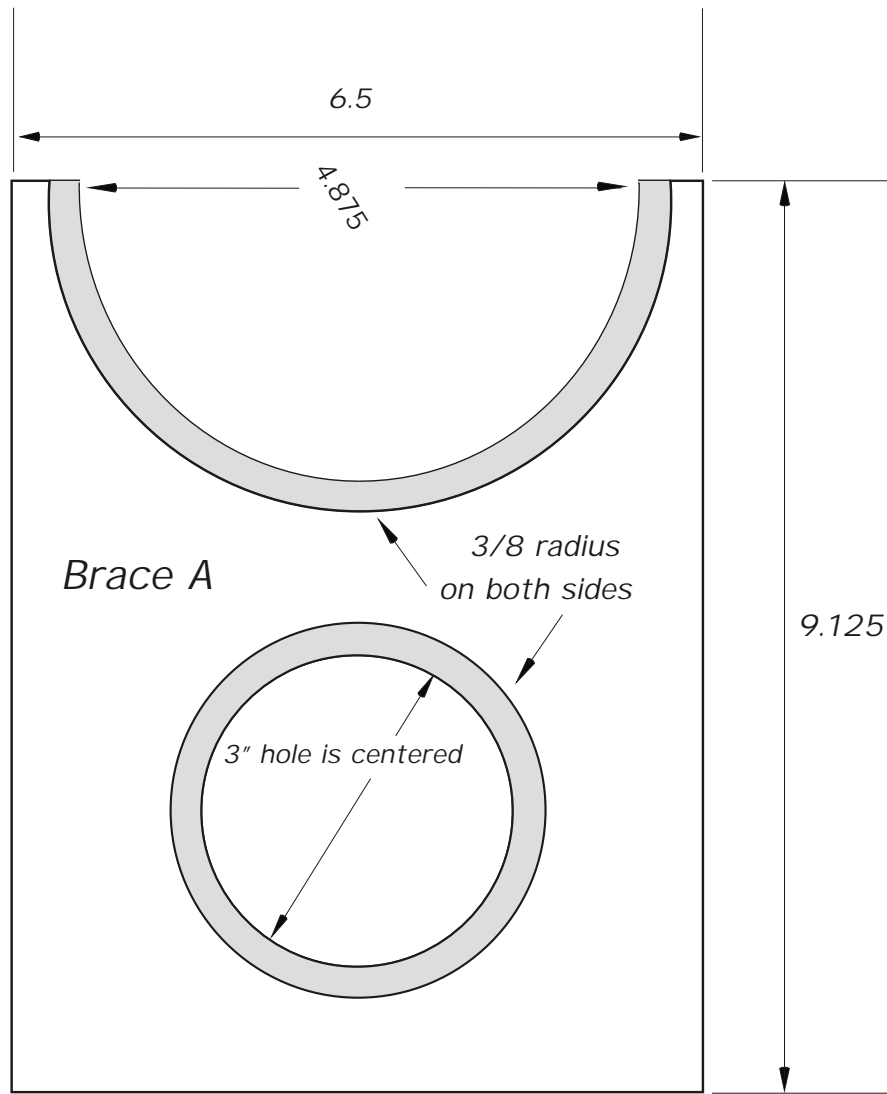

*Bond network components to the enclosure and/or bracing using liquid nails or equivalent.*