

Front baffle

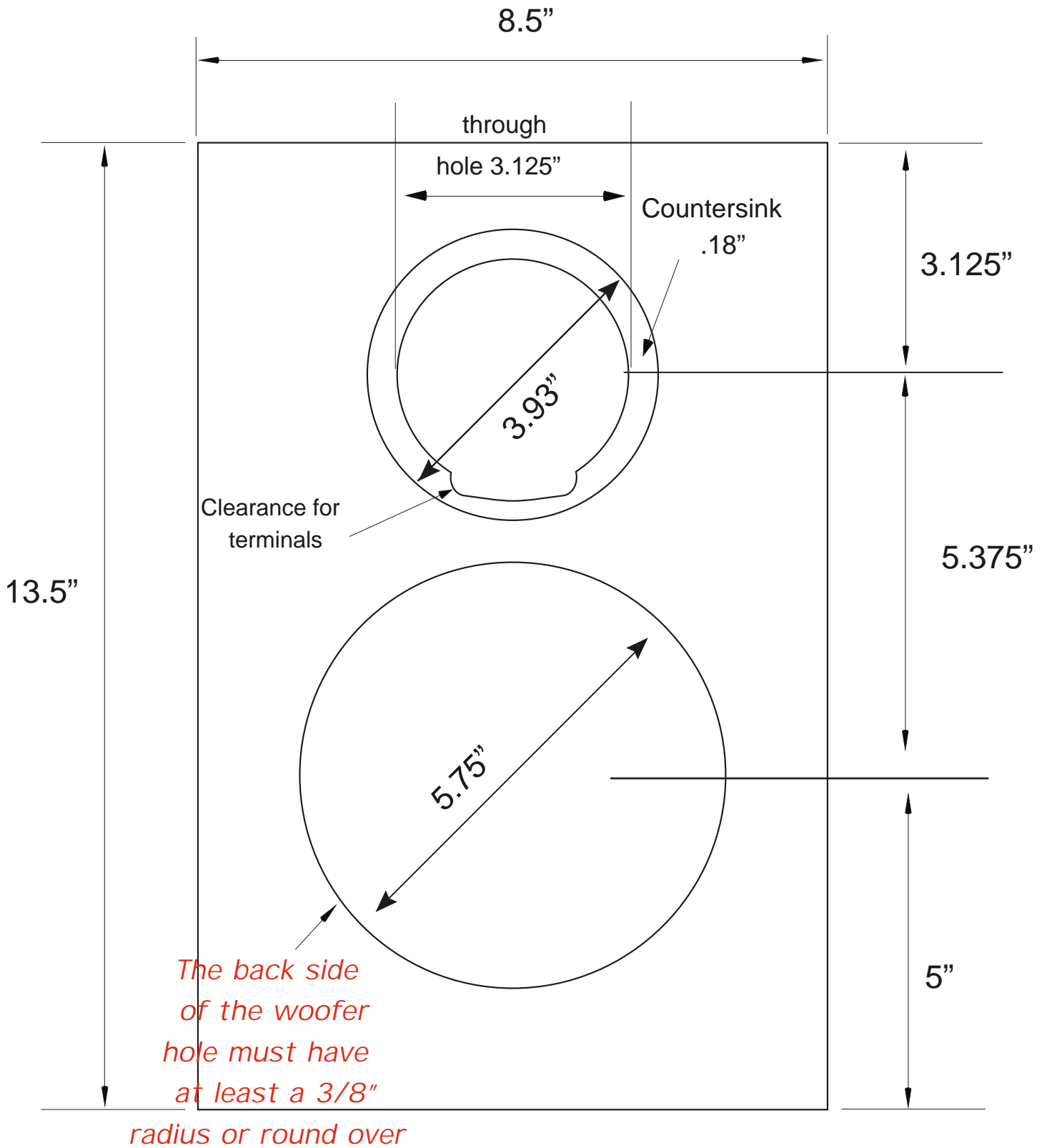

Side View

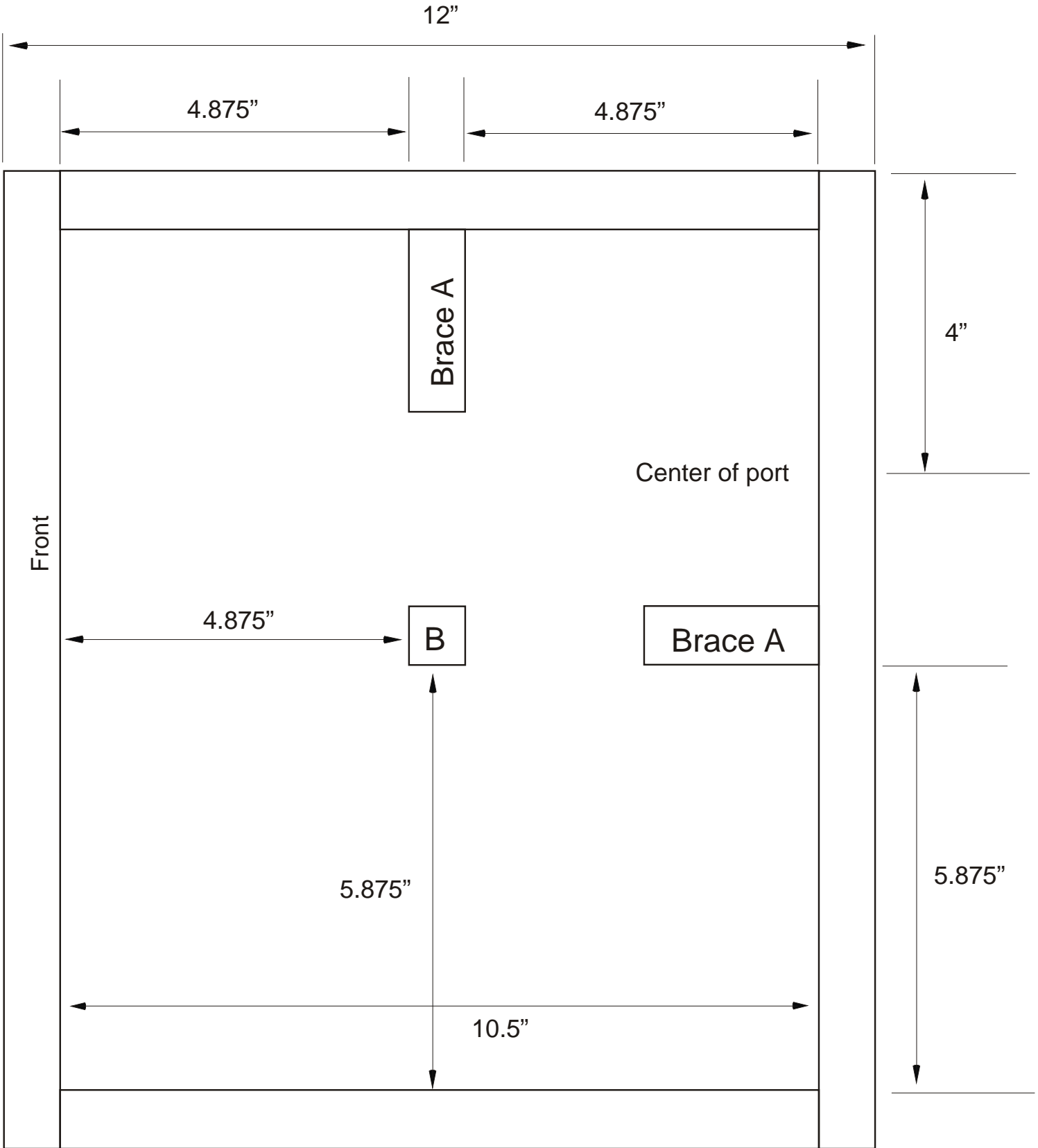

Front View

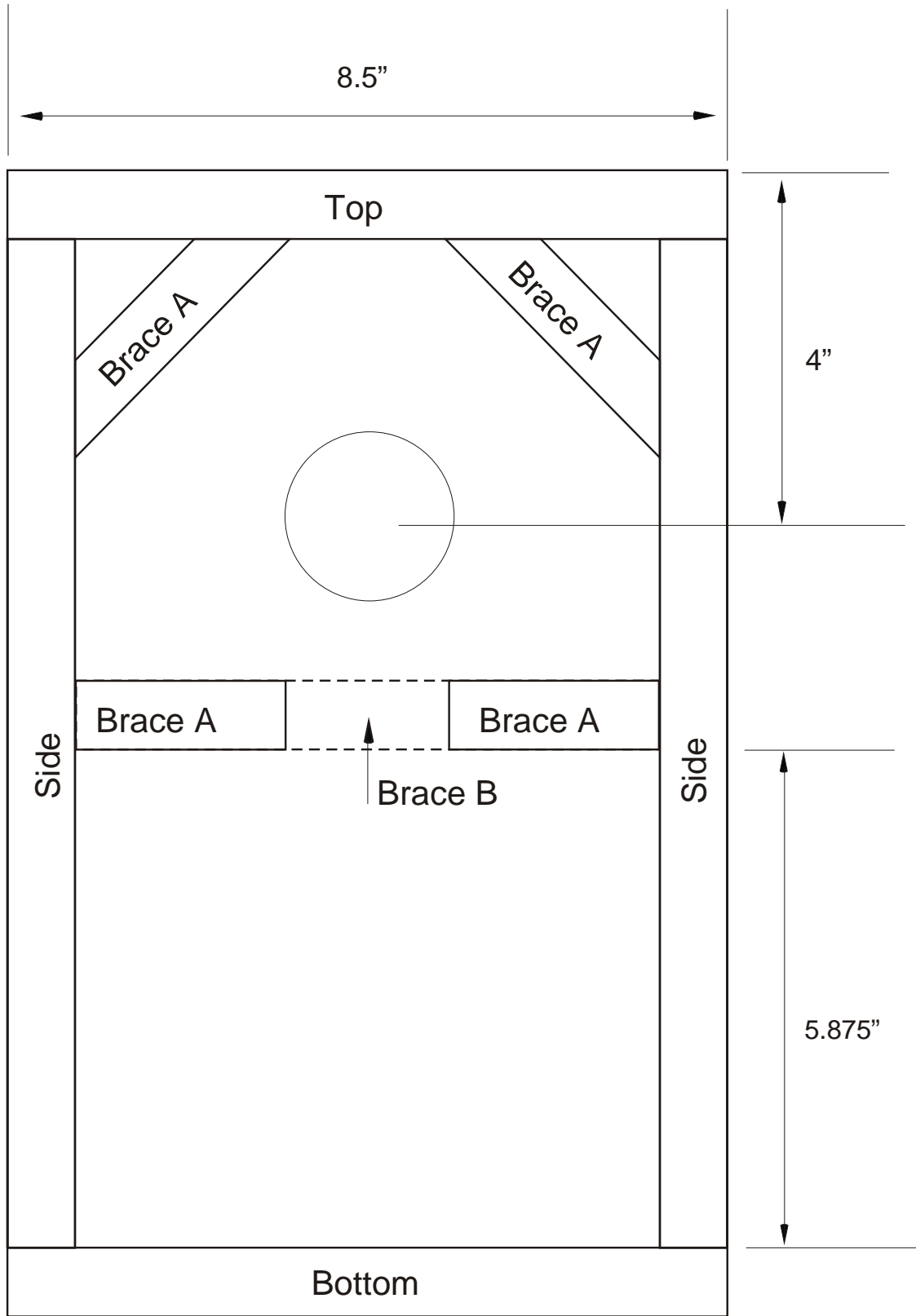

Back Panel with binding posts cup

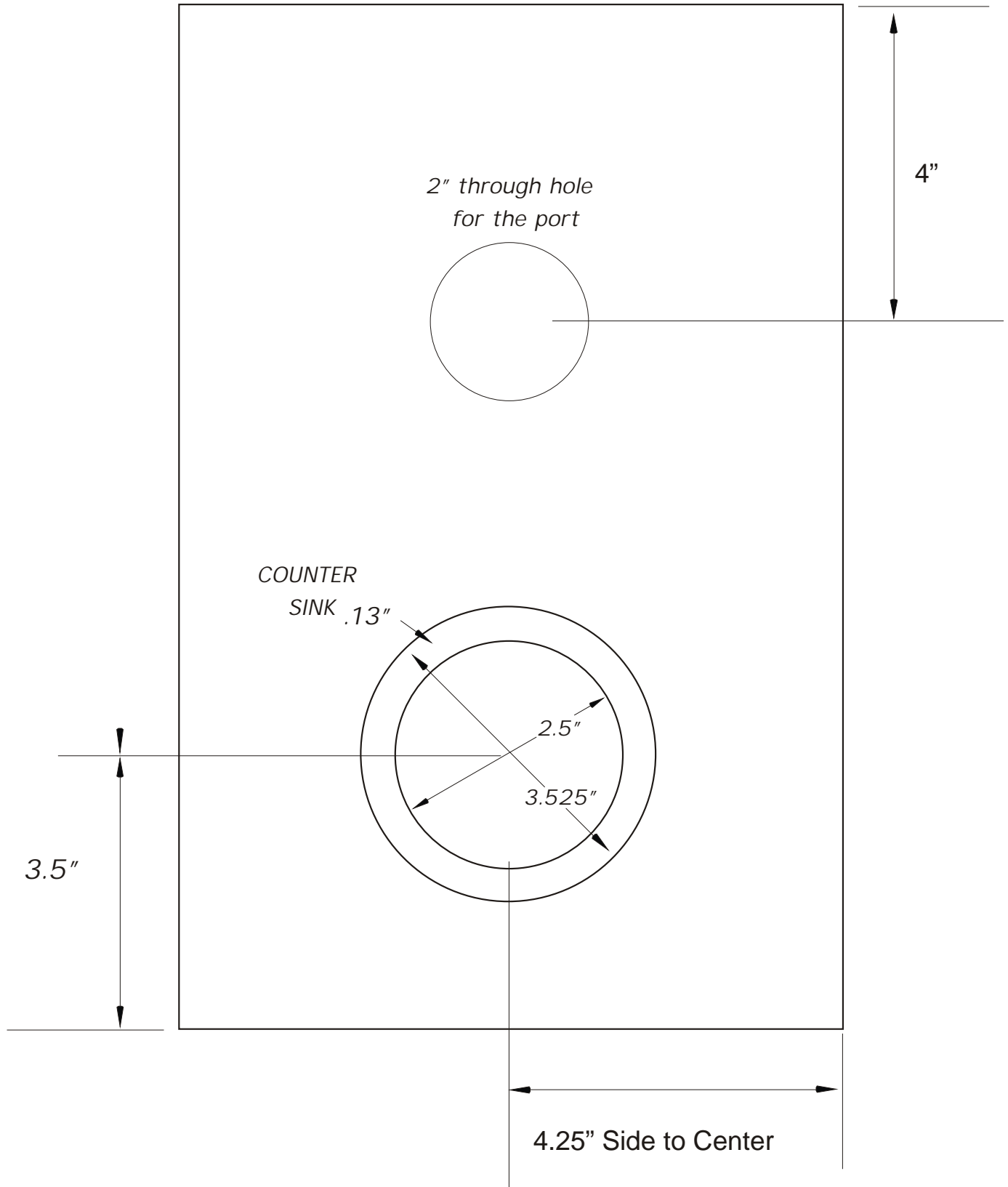

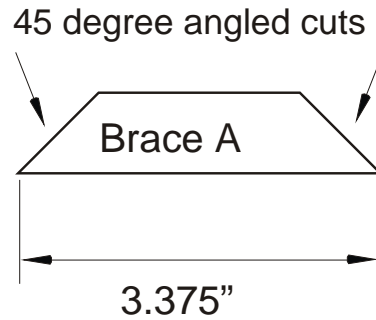

Cut list

Top/Bottom - 8.5" wide by 10.5" deep

Sides - 12" tall by 10.5" deep

Front/Back - 13.5" tall by 8.5" wide

Brace A - 3.375" long by 3/4" by 3/4"

Brace B - 7" long by 3/4" by 3/4"

Braces are designed to be glued in using Liquid Nails. Exact placement is not critical. Lining the Box with No Rez is highly recommended.